

REV	ECN	CHANGE DESCRIPTION	ENGINEER	DATE	APPROVED
C			BRO	Apr-18-24	

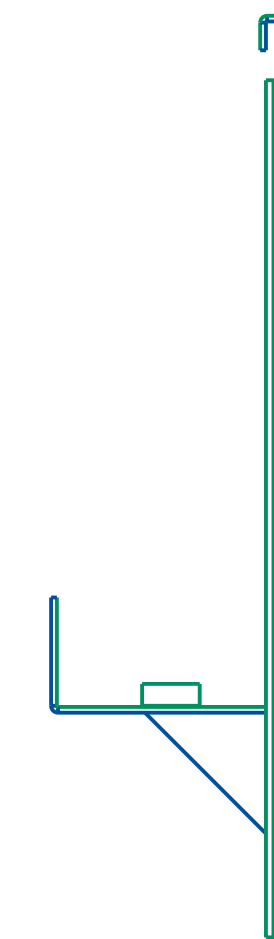

UNLESS OTHERWISE SPECIFIED
 DIMENSIONS ARE IN DECIMAL INCHES
 TOLERANCES
 ANGULAR: MACHINED $\pm 0.5^\circ$ BEND $\pm 1^\circ$
 ONE PLACE DECIMAL: $\pm .03$
 TWO PLACE DECIMAL: $\pm .010$
 THREE PLACE DECIMAL: $\pm .005$
 BREAK SHARP EDGES: $.01-.02R$

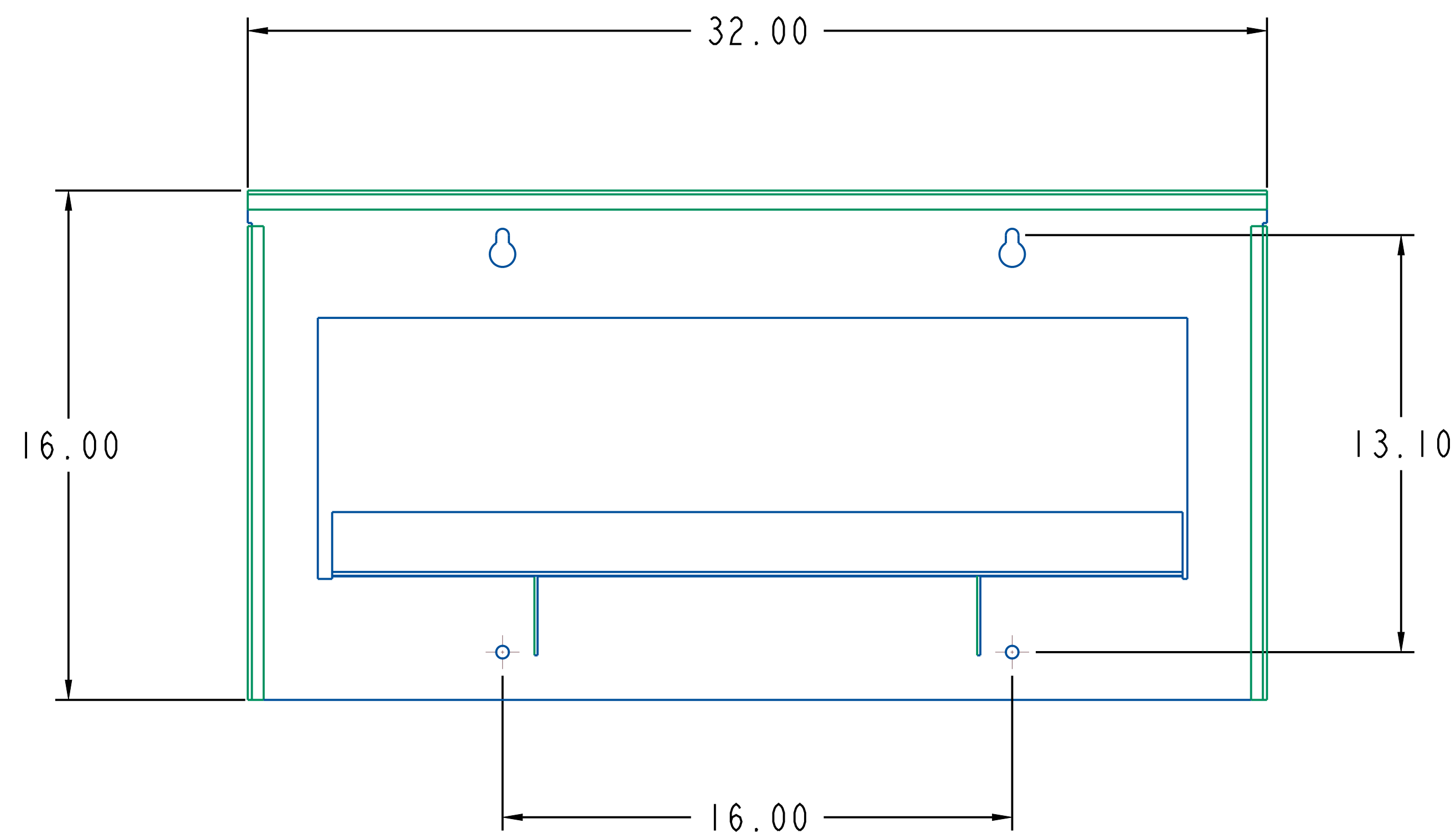
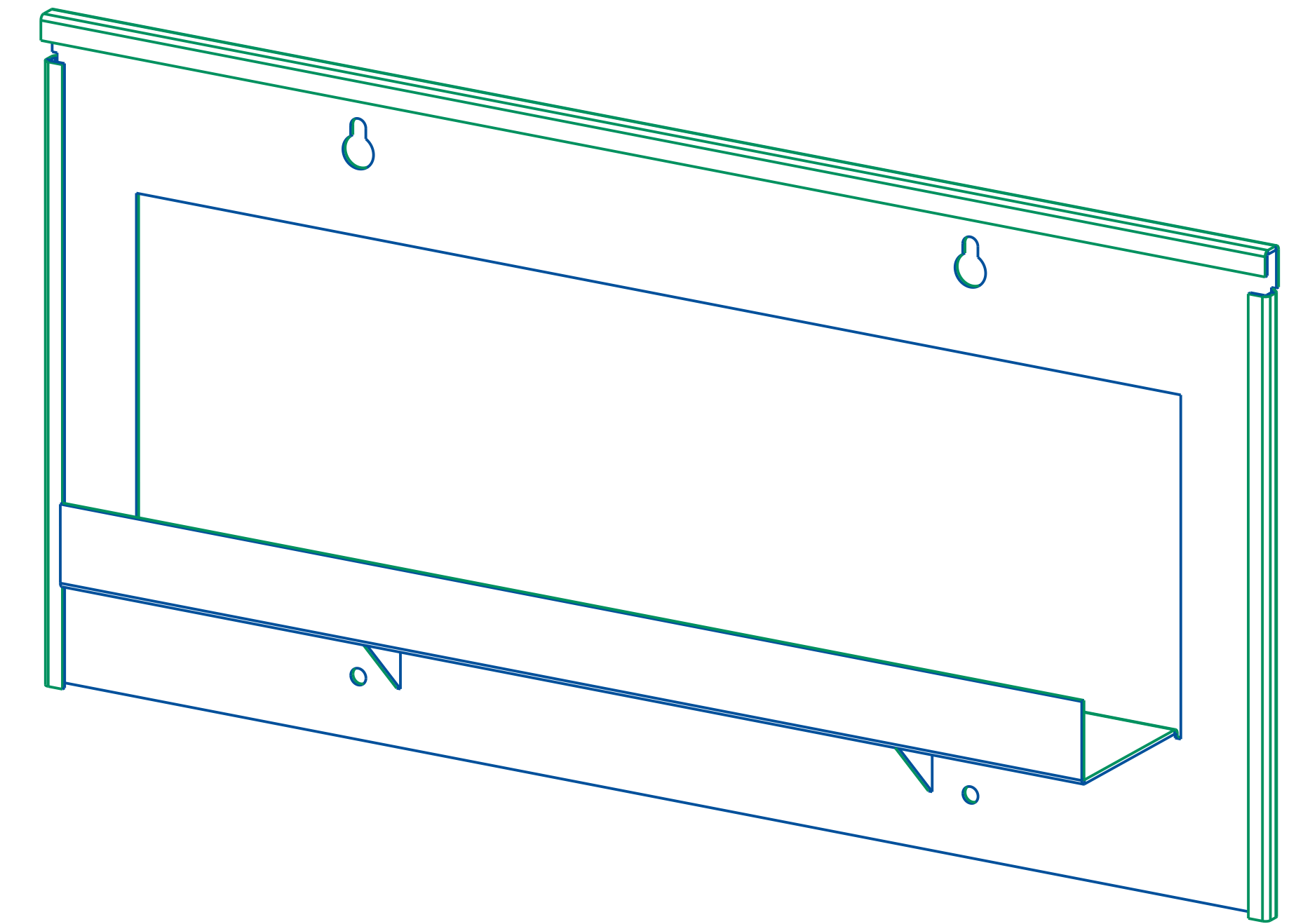
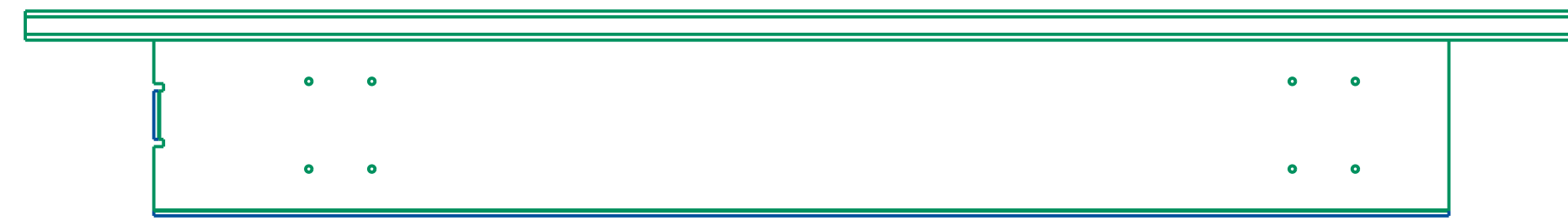

NXT POWER PART NO. 001-00095-01-FNL		MATERIAL: 12 GAUGE SHEET STEEL (CRS) 0.01"		
DESCRIPTION: RT UPS WALL MOUNT		FINISH: POWDERCOAT MATTE BLACK		
INITIATOR: BRO	REVISION: C	SIZE: D	SCALE: 0.200	PAGE: 1 of 1